

ReadyCall™ Quick Guide

Using Your ReadyCall

Battery Installation

Step1: Remove the battery door by loosening the locking screw using a screwdriver.

Step2: Follow the "+" and "-" markings on the rechargeable battery, and insert it into the pager's battery compartment.

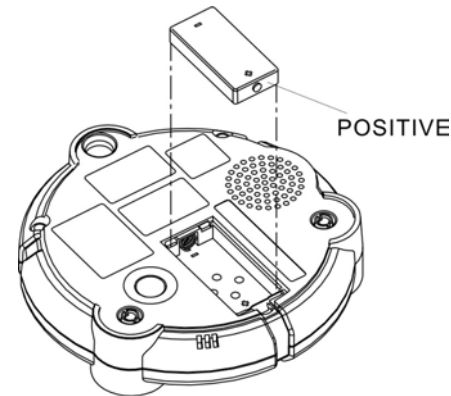

Note: Do not install the battery backwards.

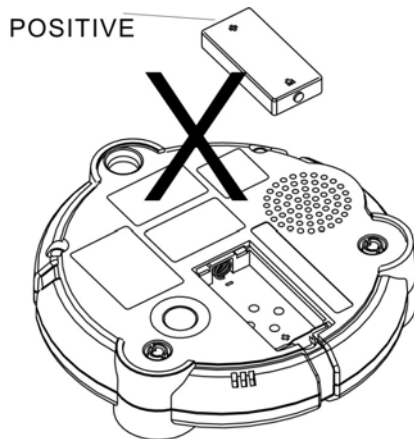

Step3: Put the battery door back and secure it by tightening the screw using a screwdriver.

Step4: After battery is inserted correctly, the pager will beep, flash and vibrate simultaneously to show the pager is powered.

Charging ReadyCall Pagers

Step 1: Connect the adapter to wall power outlet (110-240V / 50Hz-60Hz), and connect the adapter to the charger.

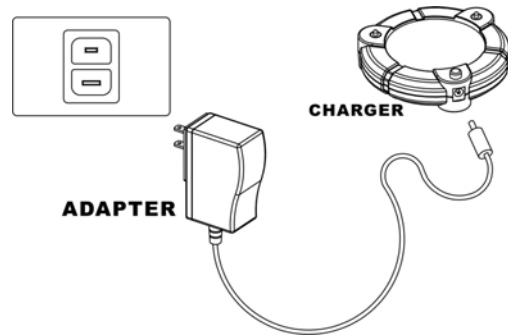

Step 2: When the charger is powered, charger power LED will illuminate to show it is on.

Step3: Place the pagers on the charger by lining up the charge contacts and lightly pushing the pager down into position one on top of the other.

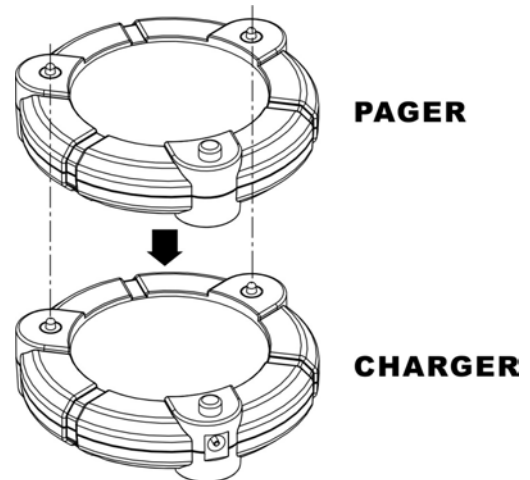

Step4: The pager power LED will go on when the pager is stacked correctly.

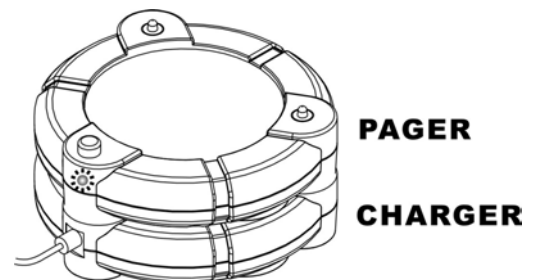

Note: It is suggested that users should implement a system or strategy for rotating pagers being issued. For example, users might use pagers that have been connected to the charger base for longer periods of time. This will allow those pagers being returned to have enough time to charge before being issued to the next recipient.

Note: The charger base supports a maximum of 10 ReadyCall pagers.

Other Functions

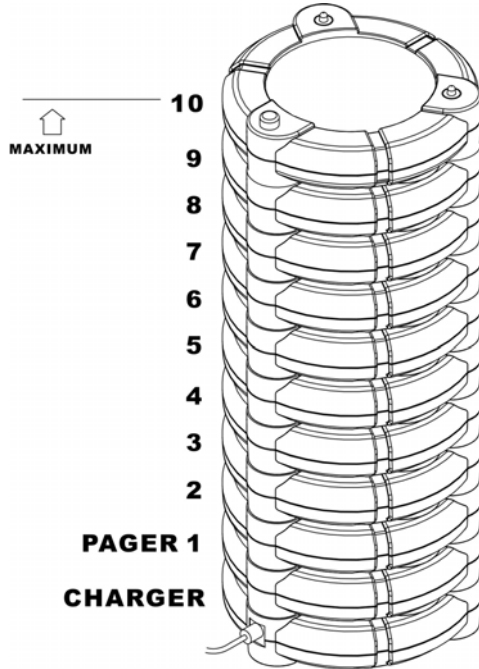

Reset button

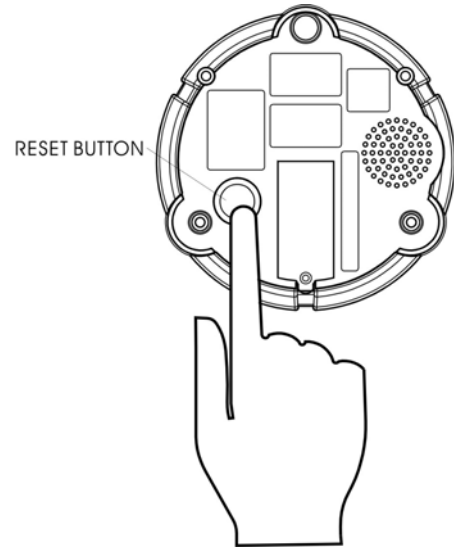

To stop the audible and vibrate alert, press **Reset button**.

Charging Status

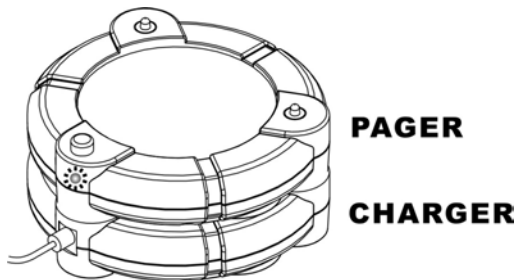

- While charging, the pager power LED will be on.
- When the charging is completed, the pager power LED will turn off.
- The pager battery can only be charged while it is in the pager.

Battery Gauge Status

ReadyCall power LED will flash regularly when powered and change to 1/4 second flash rate with a low battery.

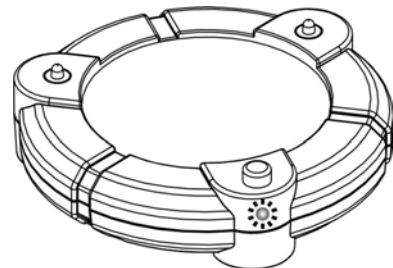

When Paged

When the pager is paged, it will alert. After pressing the reset button to stop the audible and vibrate alerting, the LEDs will continue flashing, to show that it was paged, until the pager is returned to the charger base.

Visit us @ www.usamobility.com

USAMOBIITY
ONE SOURCE FOR WIRELESS